

## Cimarron Model P

Retail Price...\$518



**Our recommendation: Buy it.**

### SPECIFICATIONS

Warranty: Lifetime Ltd.

METAL FINISH .....	"Original"	SIGHT RADIUS .....	5.75 in.
WEIGHT (EMPTY) .....	36 oz.	CAPACITY .....	6 rds.
OVERALL LENGTH .....	10.25 in.	GRIP MATERIAL .....	Walnut
OVERALL HEIGHT .....	5.1 in.	OPTIONAL GRIPS .....	No
MAX. WIDTH .....	1.6 in.	ACTION TYPE .....	SA
BARREL LENGTH .....	4.75 in.	TRIGGER PULL WT. SA .....	5 lbs.

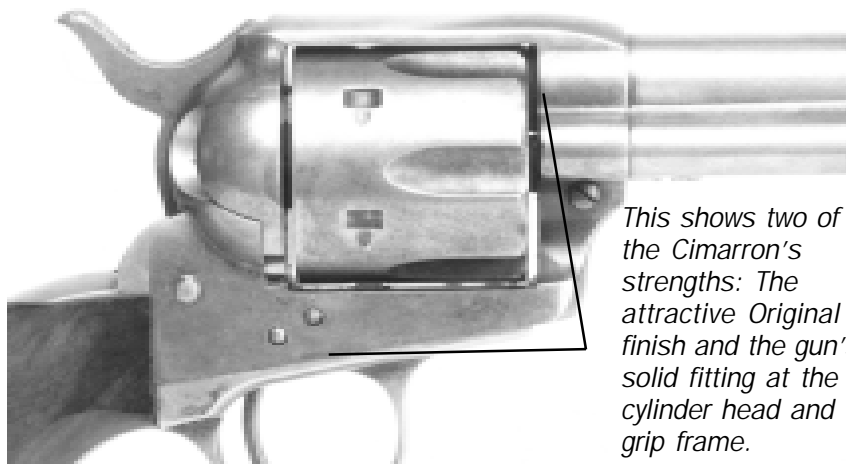

*This shows two of the Cimarron's strengths: The attractive Original finish and the gun's solid fitting at the cylinder head and grip frame.*

*Right: When the shooter draws the Model P, he gets the sensation of putting his hand inside the gun, not on it. It appears to have been constructed by hand with circa-1870 tools.*

*Below: One of the other nice visual elements of the P is its lines, helped by touches like blending the ejector rod housing into the barrel.*



finish is so convincing you'll want to claim it's an original and feel good about lying.

At an actual purchase price of \$518 the Cimarron Model P is \$100 more than the Ruger Vaquero, and \$200 more than the EAA Bounty Hunter price. (This gap narrows if you include \$100 to put the Bounty Hunter in better working condition.) What do you get for the extra money? To begin with, the finish of the Model P, made by Aldo Uberti, is thoroughly antique. The metal finish, called "Original" by importer Cimarron, appears to be in the white, but is actually a protected finish that won't rub off. The wood grips are completely blended into the frame so much so they don't even look removable. While the metal shows patterns of "natural" discoloration, the grips show faint dents and lines that might well have been earned in a gun fight or two, or perhaps from being set down authoritatively on a poker table. While the Bounty Hunter's ejector tube was screwed loosely to the barrel and the Ruger's was tightly held in place, the ejector assembly on the Model P is actually blended in. The entire pistol flows together, unlike the others. For example, when holding the Ruger and the EAA products, you are aware of the front strap, the grip panels and the way they meet the trigger guard. The Model P's construction gives the illusion of putting your hand inside the gun, not on it or around it. The trigger and hammer match the rest of the gun (unlike the Ruger), so none of the metallurgy seems modern or incongruous with the rest of the gun. It appears to have been constructed by hand with tools indigenous to the time in which it was first designed. The Model P's hammer features a nose piece set into the hammer that reaches through the breech face to ignite rounds. This shouldn't be news, but since most of today's modern revolvers, including the other so-called cowboy guns in this test,